

DRAINS, SUMPS & GRATES

FLOOR SUMP
AT1HST



Exploded View showing removable Grate, Basket & Fixed Strainer

FEATURES

- Stainless Steel Grade 304
- Hinged Grate
- Removable Basket - Large 4.3 Litre Capacity
- Fixed Tertiary Strainer prevents solids discharge to Sewer

OPTIONS

- Extra Heavy Duty Grate (3 Tonne Loading) Use Model AT1HSTHD
- Shallow Body Model – Use Model AT1HST1005
- Available with Silt / Sediment Baskets
- Vinyl Clamp for use with Vinyl Floor Finish
- Puddle Flange
- Wired in Basket to Minimise Basket Loss & Ensure Use



WaterMark



DRAINS, SUMPS & GRATES

FLOOR SUMP

AT1HST

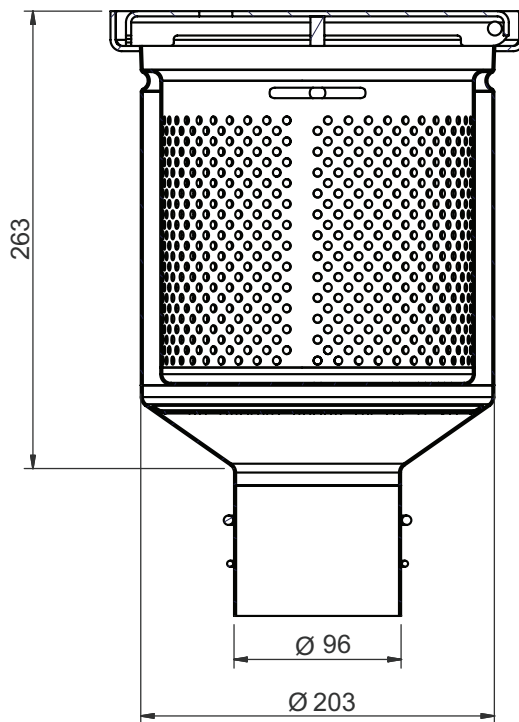
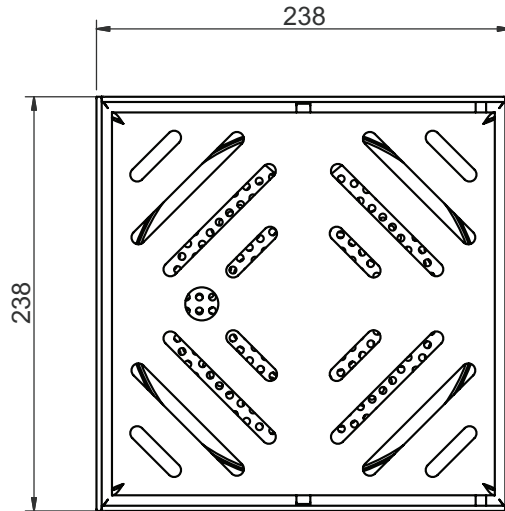

SPECIFICATIONS

Stainless Steel Floor Sump shall be Model AT1HST
from Opie Manufacturing Group
Phone 02 4735 5666